

FLATGRID

Installation manual

Creation/revision date

2020.03 / V.001

Product

SCHLETTER FlatGrid

Manufacturer and address

Schletter Solar GmbH

Alustraße 1

83527 Kirchdorf

Germany

Tel.: +49 (0)8072 / 9191 0

Fax: +49 (0)8072 / 9191 9100

www.schletter-group.com

anfragen@schletter-group.com

FlatGrid

Installation manual

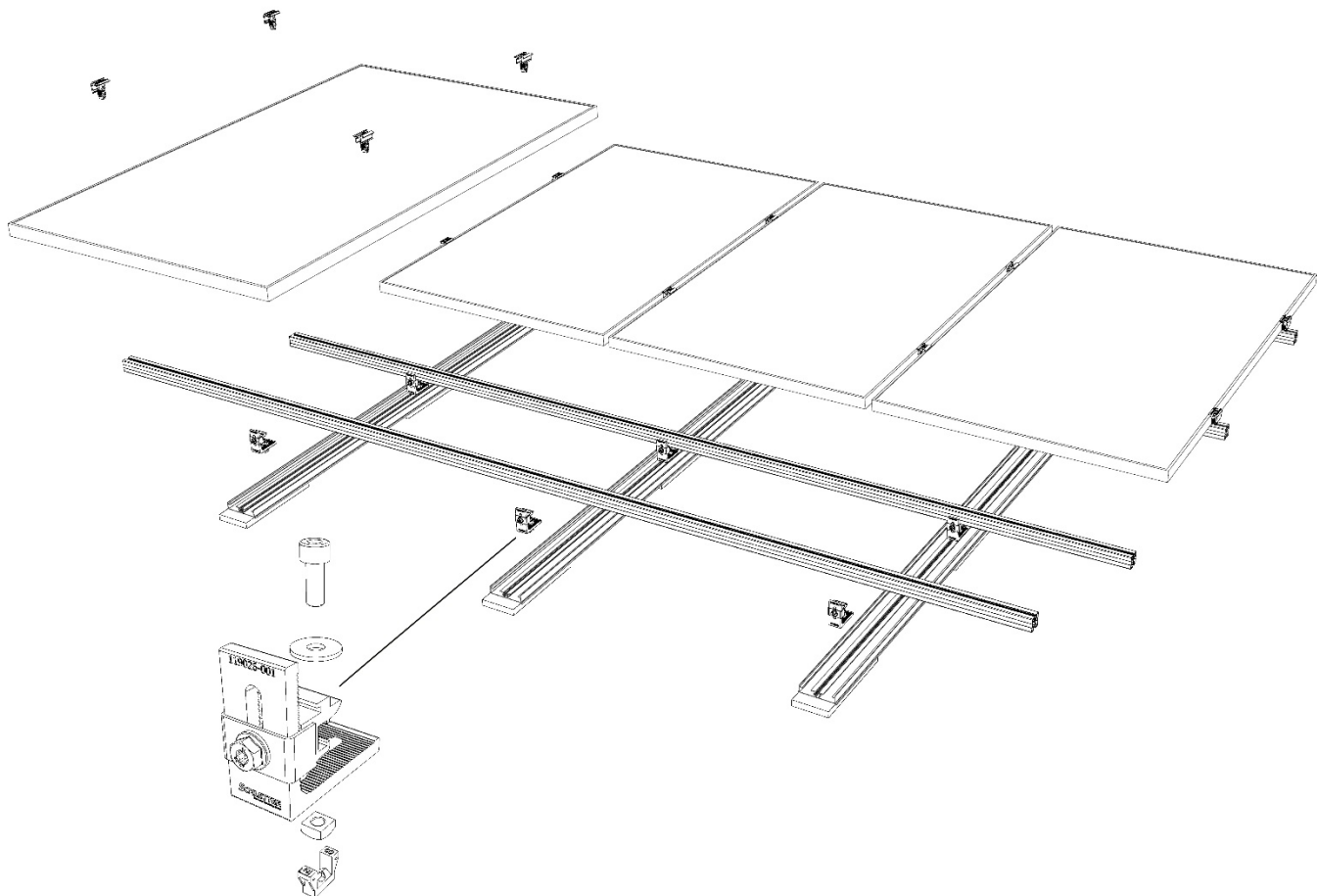

Tools needed

Tape measure

Screwdriver with bit socket,
SW6 Allen screw bit

Torx T40 bit

Other documents needed

General assembly instructions –
Assembly and project planning

FlatGrid product sheet

Tightening torques

M8 screw connections: 15 Nm

Safety instructions



The system is to be installed only with ballasting according to the design documents. You can get these from us with our system design, or directly through software in the download area at www.schletter-group.com.



Breakage hazard! PV modules can be damaged if they are stepped on.



Planning of the photovoltaic system, installation and commissioning may be done only by qualified technical personnel. Improper installation can cause damage to the system and endanger people.



Electrical hazard! Installation and maintenance of the photovoltaic system is to be done only by qualified technical personnel. Observe the safety regulations of the PV module manufacturer!



Falling hazard! There is a risk of falling when working on the roof and when climbing up and down. It is imperative that the accident prevention regulations be observed and that suitable fall protection devices be used.



Injury hazard! People may be injured by falling objects. Before starting the installation, block off any danger zones and warn people nearby!

Installation instructions



For very uneven roofs or roofing strips, compensation measures may be needed to ensure even application of the load.



Necessary distances to roof edges must be maintained.



Due to linear thermal expansion, the main beams must be separated by reasonable distances. A recommended reference value for the maximum bar length on foil roofs is 10 m.



FlatGrid is not recommended for roofs with more than a 10-degree slope. For slopes of 3° and more, additional fastening may be needed on the roof.



The surface load must not exceed the building's residual load capacity!



For static reasons, at least two contiguous rows of modules must be installed. If this is not possible, please contact Technical Advice.



Please follow any project-related instructions in the planning documentation!

1 Extension of base profiles

- Extend the base profile as needed.
- To do this, insert the internal connector into two profiles and fasten it at both ends with two self-drilling screws.

Tool:

Screwdriver with 8 mm plug attachment

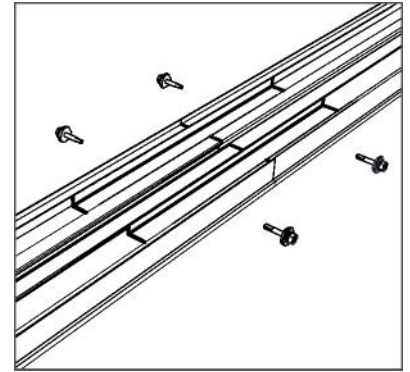
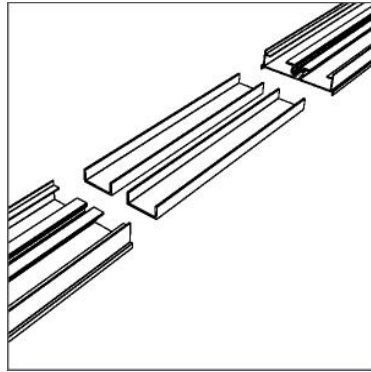

2 Installing the structure protection mat

- Adhere the structure protection mat strips to the existing base profile after removing the protective film.
- Observe at least a 30 mm projection for the structure protection mat at the ends of the profiles.

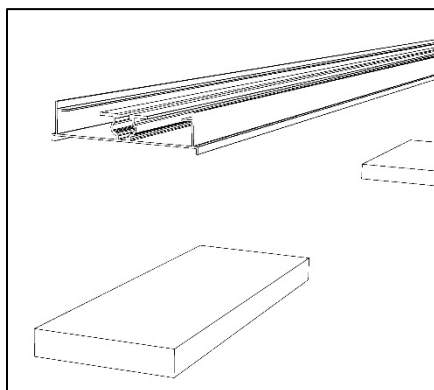

3 Alignment of the base profile

- Place the finished base profiles parallel to each other on the roof in the direction of the ridge eaves.
- The distance between the profiles should match static specifications.

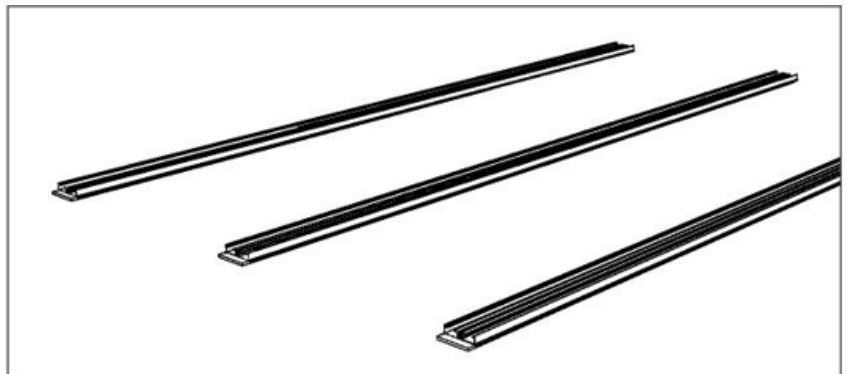

4 Installing Rapid 2+ L

- Press the one-click module and square nut into the space provided in the base profile.
- Place Rapid 2+ L onto the profile, align it, and fasten it with a screw and shim.

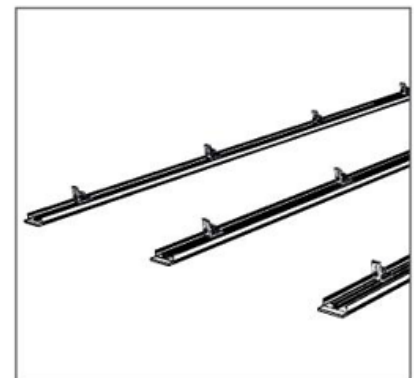
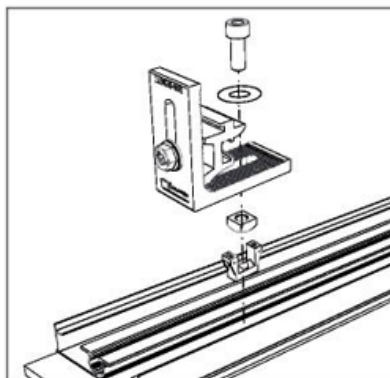

5 Slip protection

- For sloped roofs, module fields must be secured against slipping. Either through horizontal fastening or coupling of opposite tension connectors using the tension connector on the ridge. To do this, thread the connectors into each other, press them together at the ends, and use 2 screws to fasten them from above using a one-click module and square nut on both base profiles.
- Roof fascia in certain circumstances could also offer protection against slipping. Make sure the connection and static load-bearing capacity are suitable.
- In general, for individual connections, it is a good idea to consult an engineering firm.

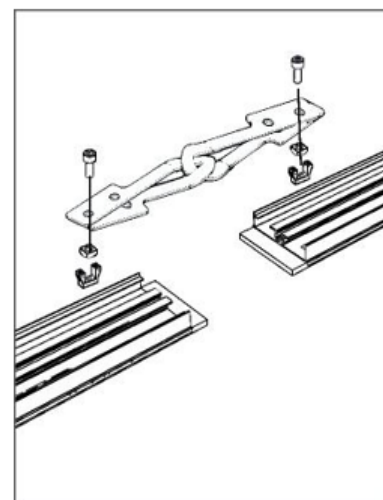
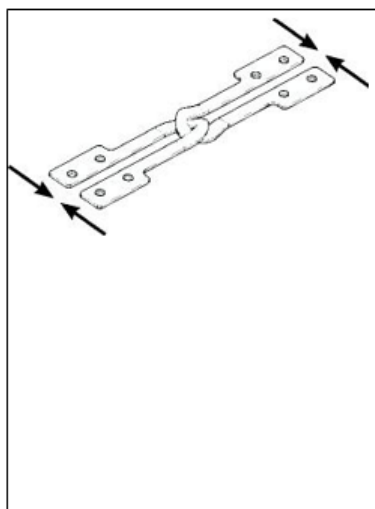

6 Installing the module support profiles

- Insert the module support profiles onto the lower screw channel in the clamp.
- Align the module support profile vertically together with the clamping part and tighten the screws to fasten.

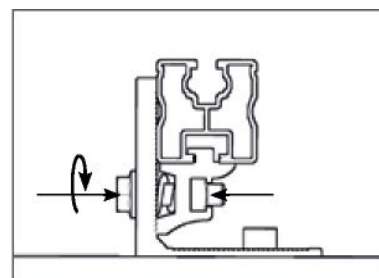
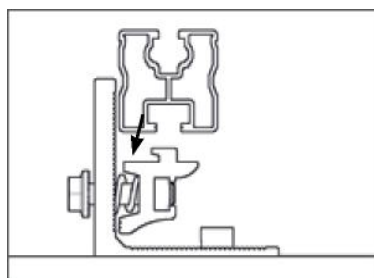
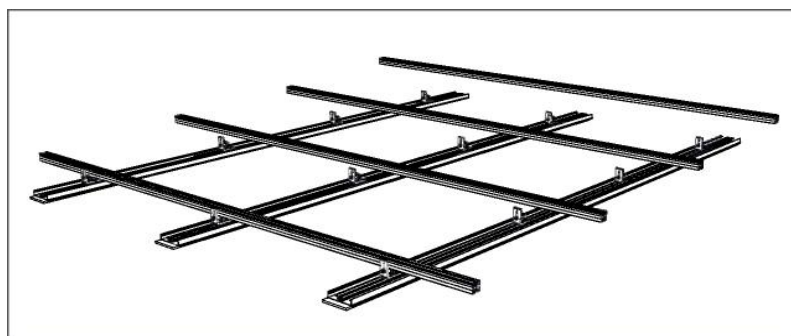

7 Ballasting

- Distribute the ballast according to the planning documents. You can get them from our company with the system plan or directly through the configurator in the download area of our website: www.schletter-group.com
- Distribute the ballast evenly on the base profile. If the load distribution is uneven, bring the loads close to the module support profile.



Ballast is not included with FlatGrid.
Recommended stone dimensions: 20x10x8cm

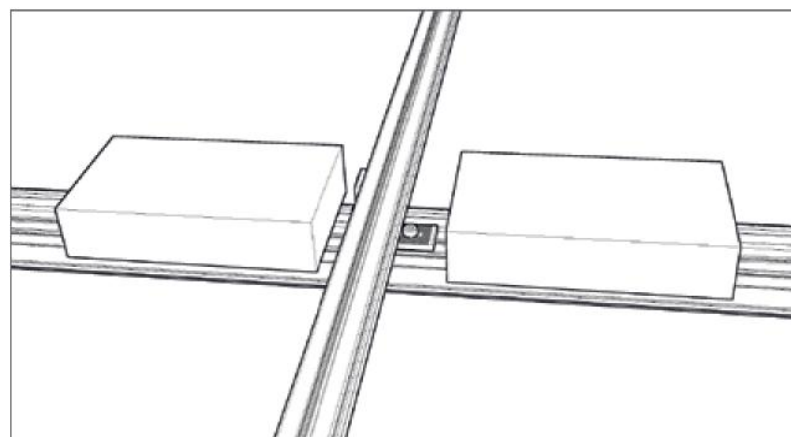

f If the base profile is not adequate for ballasting, a tray can be filled with more stones for additional ballast. Fasten the structure protection mat pieces to the trough with fastening flaps.

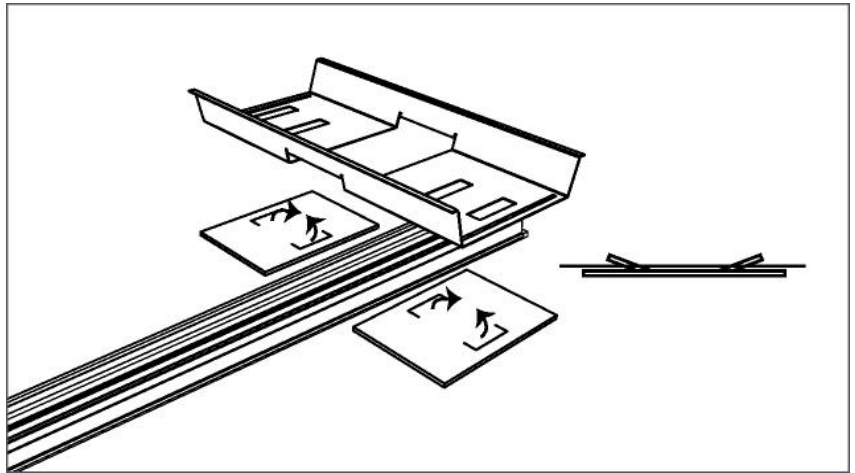

8 Fastening the modules

- Position the module on the module support profile according to the plan specifications, install the cables and fasten with Rapid16 module clamps.

⚠ Observe the module manufacturer's clamping points.

⚠ The fastening points for the module clamps can be freely chosen in the module support profile's aluminum channel. The specified torque for fastening the module clamps is 15 Nm.

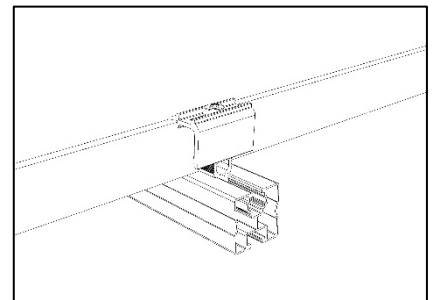
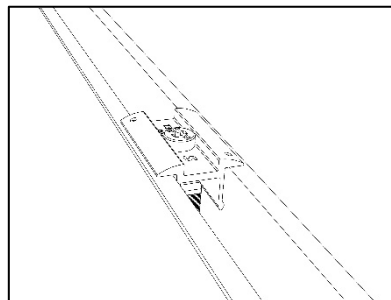
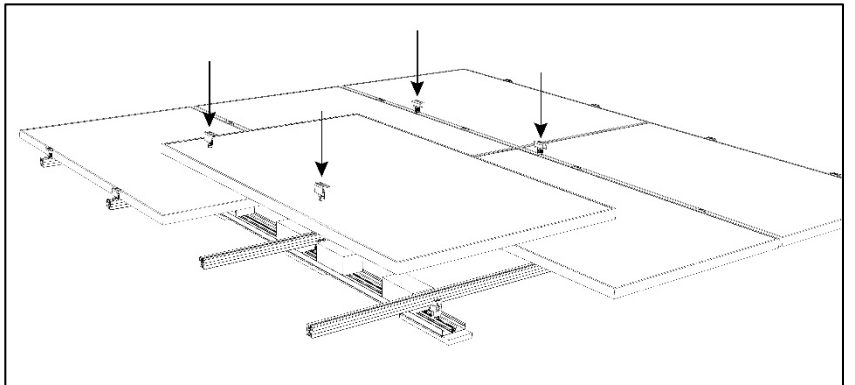

More information on our systems can be found at our website: www.schletter-group.com in the Downloads area.